

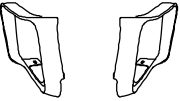

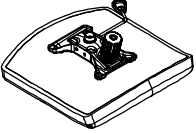

# ASSEMBLY GUIDELINE FOR WFH - GLIDE CHAIR

PART LIST			
1		BACKREST	1 pc
2		ARMREST	2 pcs
3		SEAT WITH MECHANISM	1 pc
4		BASE	1 pc
5		GASLIFT	1 pc
6		ALLEN BOLT WITH BUTTON HEAD M6 X 30	6 pc
7		ALLEN KEY	1 pc

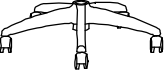

Note: 1. For chairs, use clean dry cloth to wipe fabric wrapped seats, nylon base and metal power coated surfaces

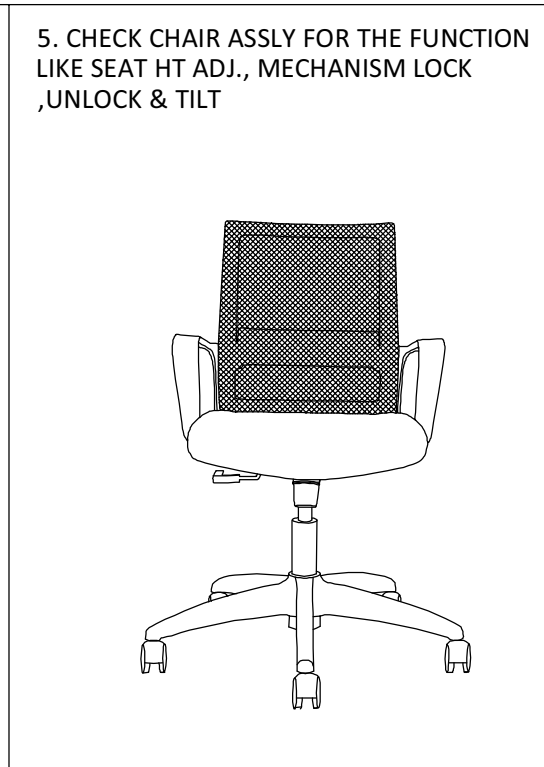
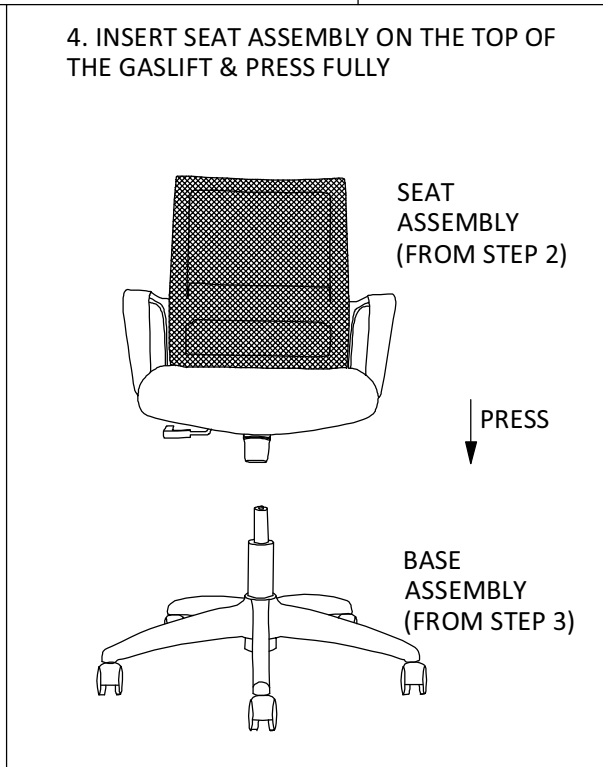
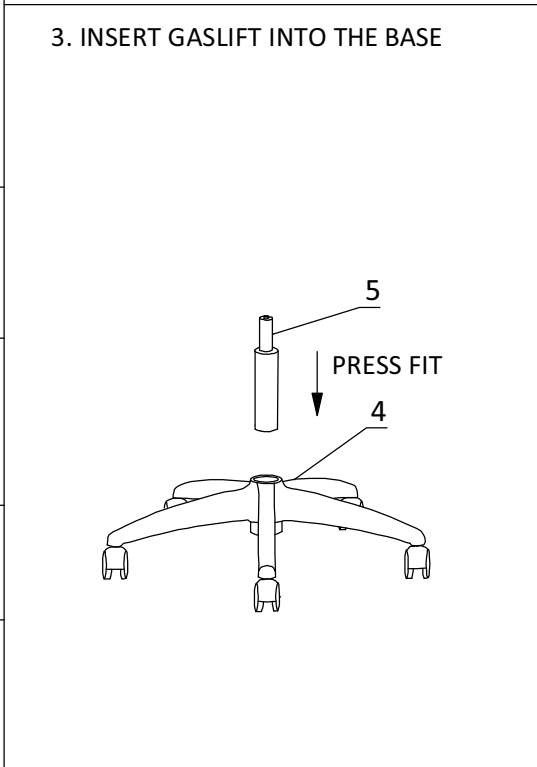
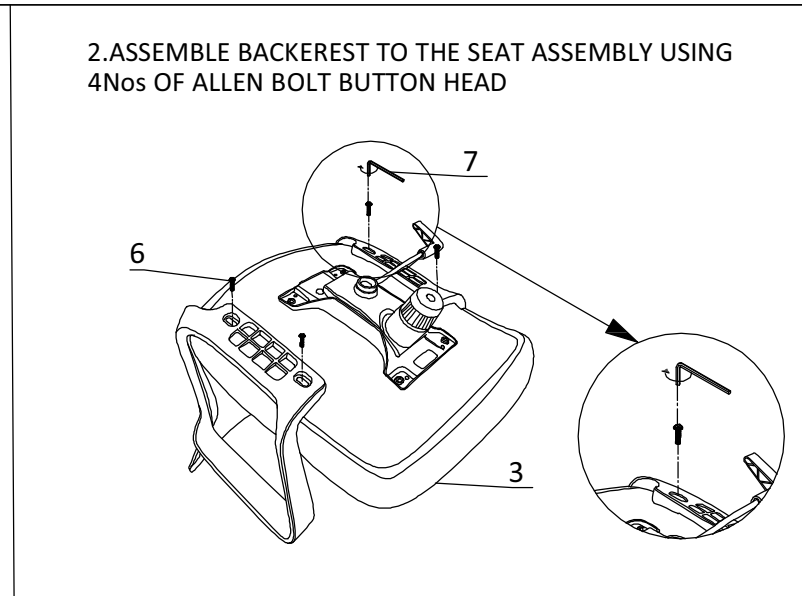
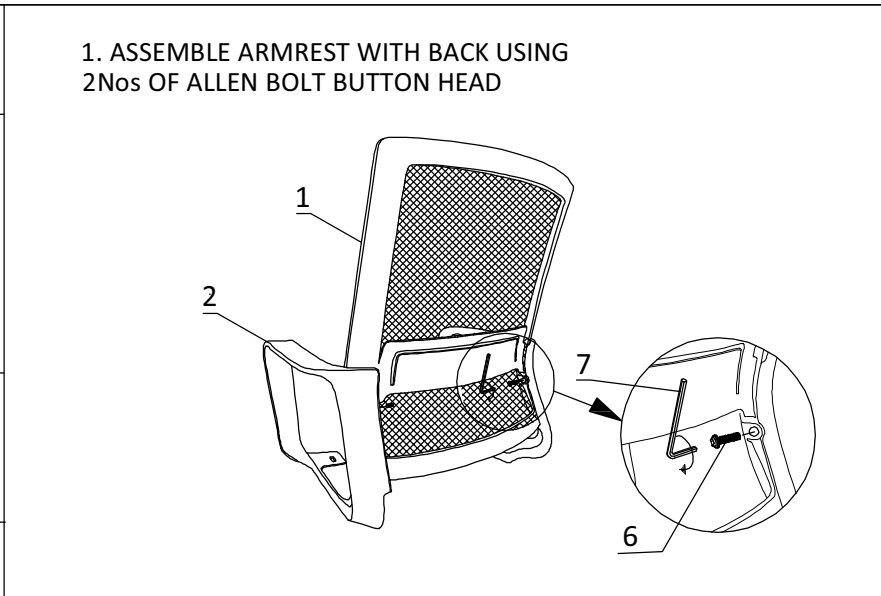
2. Vacuum cleaning is recommended once in 3 months for chairs