

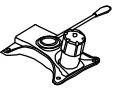

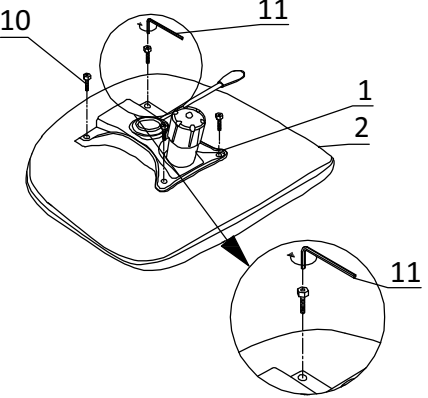

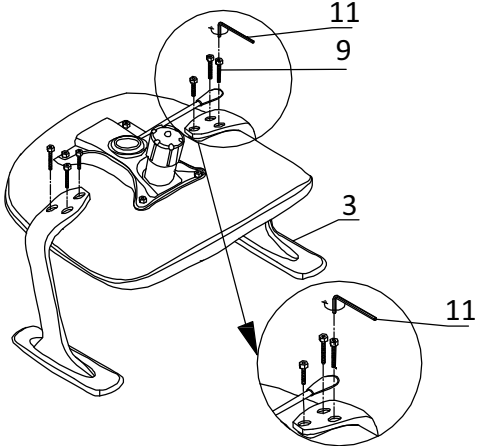

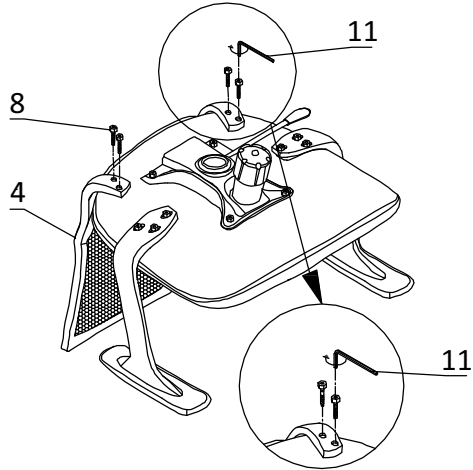

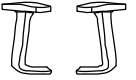
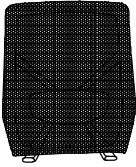
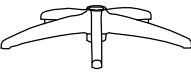

AGL FOR WFH - O-FIT CHAIR

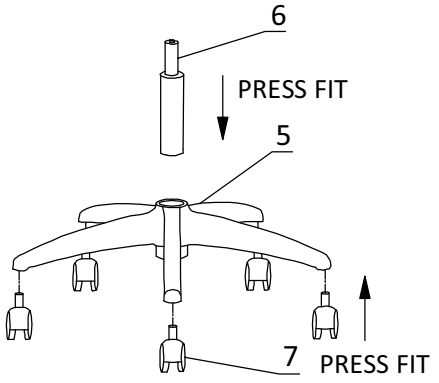
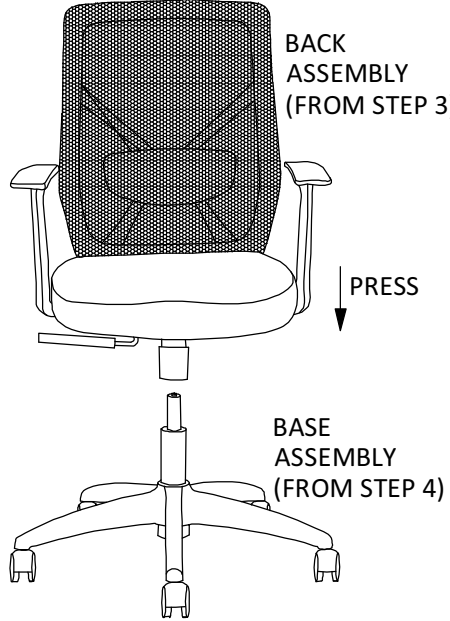
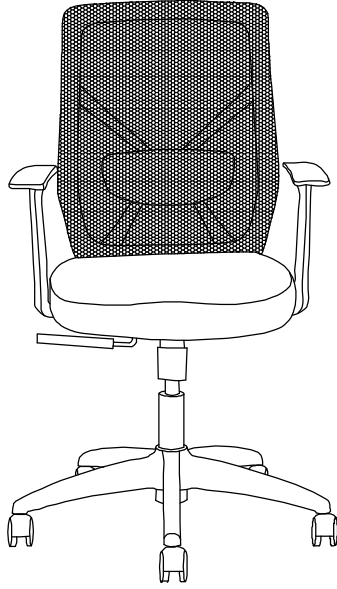
PART LIST				1. ASSEMBLE MECHANISM WITH SEAT USING 4Nos OF HEX BOLT	2. ASSEMBLE LH & RH ARMREST TO THE SEAT ASSEMBLY USING 6Nos OF HEX BOLT	3. ASSEMBLE BACKEREST TO THE SEAT ASSEMBLY USING 4Nos OF HEX BOLT
1		MECHANISM	1 pc			
2		FOAM SEAT	1 pc			
3		ARMREST	2 pcs			
4		BACKREST	1 pc			
5		BASE	1 pc	4. INSERT GASLIFT & PRESS FIT CASTOR WHEEL INTO THE BASE	5. INSERT SEAT ASSEMBLY ON THE TOP OF THE GASLIFT & PRESS FULLY	6. CHECK CHAIR ASSLY FOR THE FUNCTION LIKE SEAT HT ADJ., MECHANISM LOCK , UNLOCK & TILT
6		GASLIFT	1 pc			
7		CASTOR WHEEL	5 pcs			
8		HEX BOLT L=40mm	4 pcs			
9		HEX BOLT L=30mm	6 pcs			
10		HEX BOLT L=20mm	4 pcs			
11		ALLEN KEY	1 pc			

Note: 1. For chairs, use clean dry cloth to wipe fabric wrapped seats, nylon base and metal power coated surfaces

2. Vacuum cleaning is recommended once in 3 months for chairs

- by -