

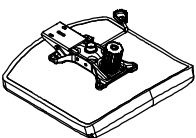

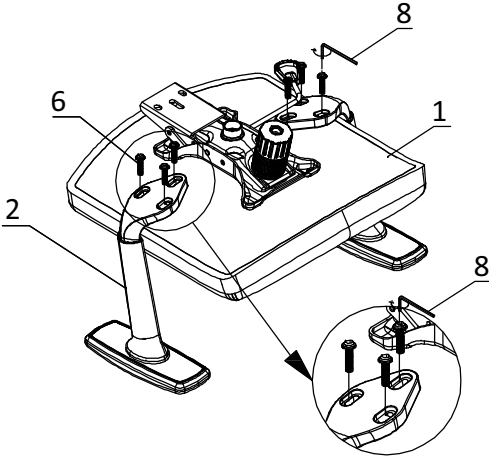
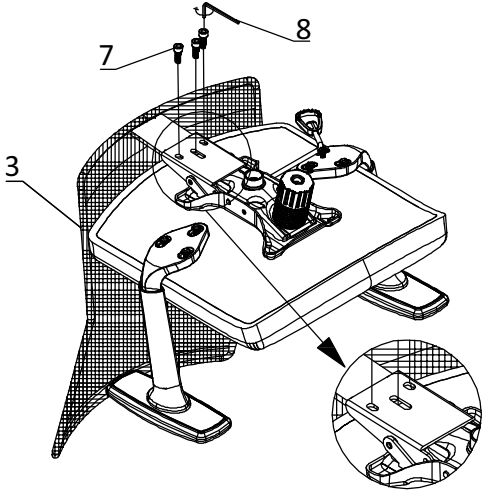
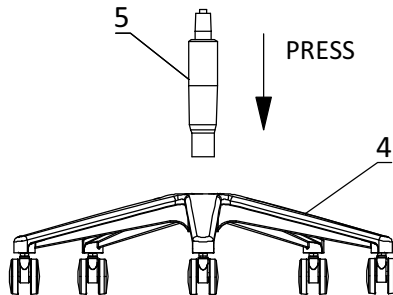
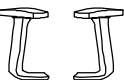
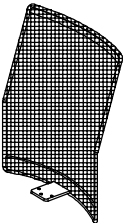

AGL FOR WFH - STEAD MEDIUM BACK CHAIR

PART LIST				1. ASSEMBLE LH & RH ARMREST TO THE SEAT ASSEMBLY USING 6Nos OF ALLEN BOLT	2. ASSEMBLE BACKREST TO THE SEAT ASSEMBLY USING 3Nos OF ALLEN BOLT	3. INSERT GAS LIFT IN TO BASE ASSEMBLY
1		SEAT & MECHANISM ASSLY	1 pc			
2		ARMREST	2 pcs			
3		BACKREST	1 pc			
4		BASE	1 pc	4. INSERT BACKREST ASSEMBLY ON TOP OF THE BASE ASSEMBLY & PRESS FULLY		5. CHECK CHAIR ASSLY FOR THE FUNCTION LIKE SEAT HEIGHT ADJ., MECHANISM LOCK , UNLOCK & TILT
5		GASLIFT	1 pc			
6		ALLEN BOLT M6X30mm	6 pcs			
7		ALLEN BOLT M8X20mm	3 pcs			
8		ALLEN KEY	1 pc			

Note: 1. For chairs, use clean dry cloth to wipe fabric wrapped seats, nylon base and metal power coated surfaces

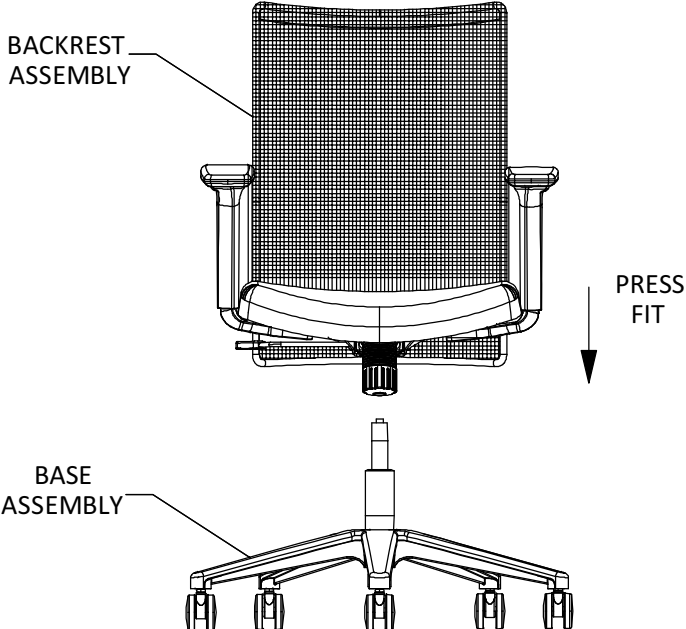
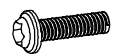
2. Vacuum cleaning is recommended once in 3 months for chairs

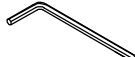
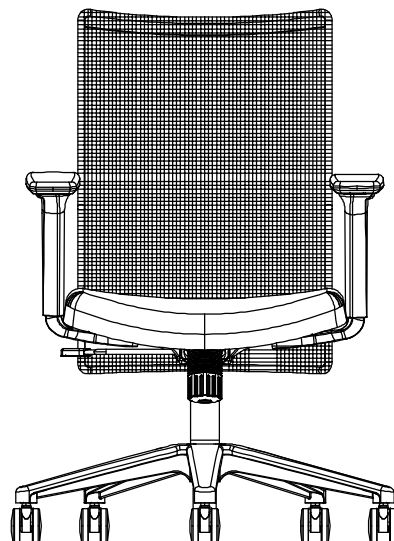
- by -