

ASSEMBLY GUIDELINE FOR WFH - WOODWING CHAIR

PART LIST			
1		FRONT SUPPORT	1 pc
2		CROSS MEMBER	2 pcs
3		REAR SUPPORT	1 pc
4		LH ARM	1 pc
5		RH ARM	1 pc
6		NUT	4 pc
7		ALLEN BOLT M6x60mm	6 pcs
8		ALLEN KEY	1 pc
9		BACKREST	1 pcs
10		SEAT	1 pcs
11		ALLEN BOLT M6x40mm	4 pc

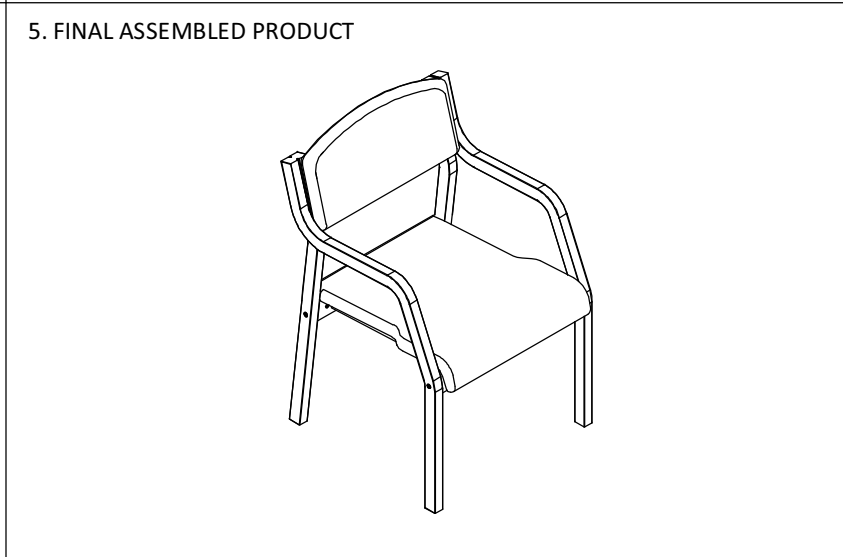
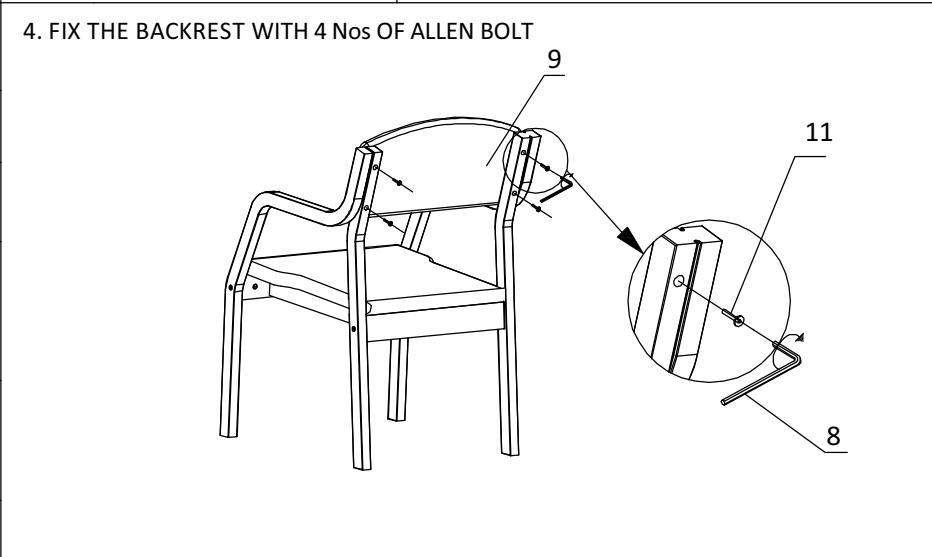
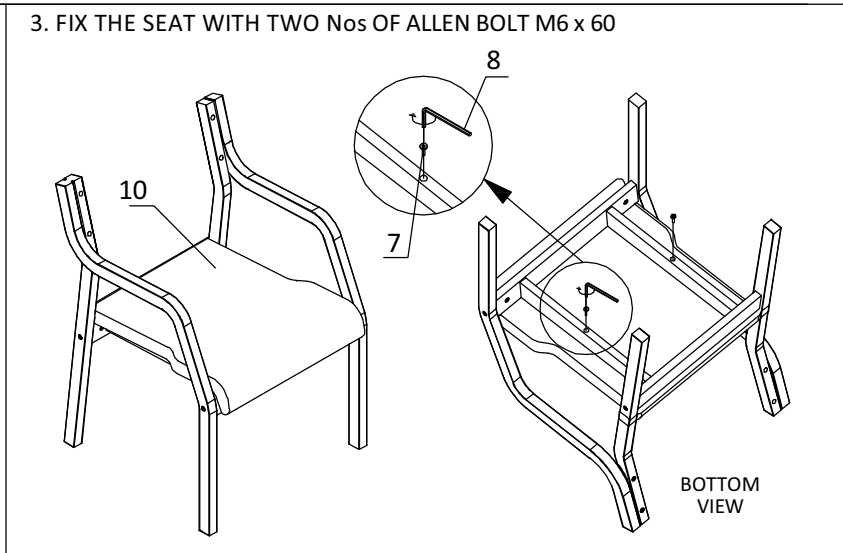
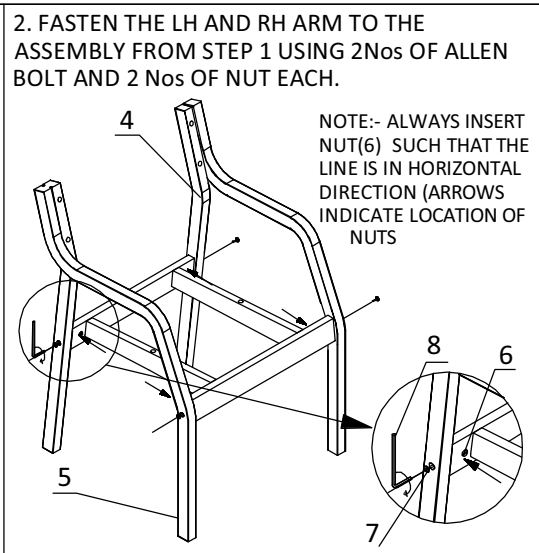
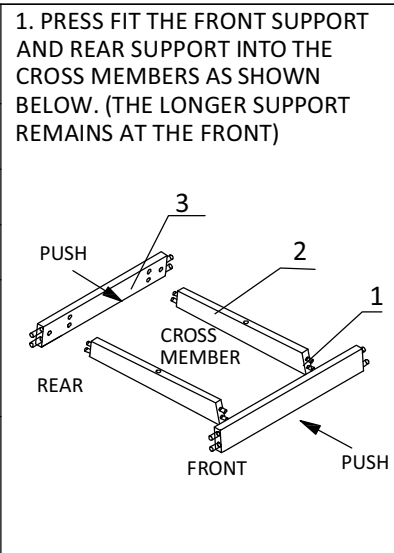

Note: 1. For chairs, use clean dry cloth to wipe fabric wrapped seats, nylon base and metal power coated surfaces
2. Vacuum cleaning is recommended once in 3 months for chairs