





ASSEMBLY GUIDE LINE FOR ECO DESK

PART LIST

1		VERTICAL LEG ASSLY	4pcs
2		LEG SUPPORT PLATE	4pcs
3		TABLE TOP	1pc
4		ALLEN SCREW CSK HEAD @ M6x16	24pcs
5		ALLEN KEY WITH HANDLE	1pc

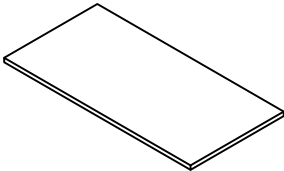
STEP 1. ASSEMBLE THE LEG WITH SUPPORT PLATE .

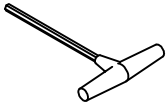
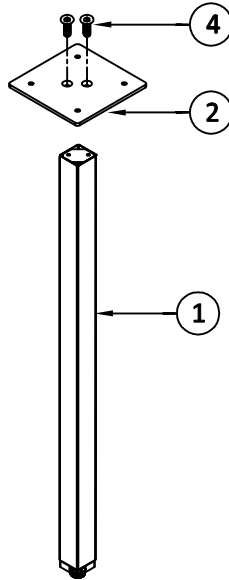

STEP 2. TABLE LEGS TO BE SCREWED TO THE TABLE TOP FROM BOTTOM SIDE WITH THE HELP OF SCREW .

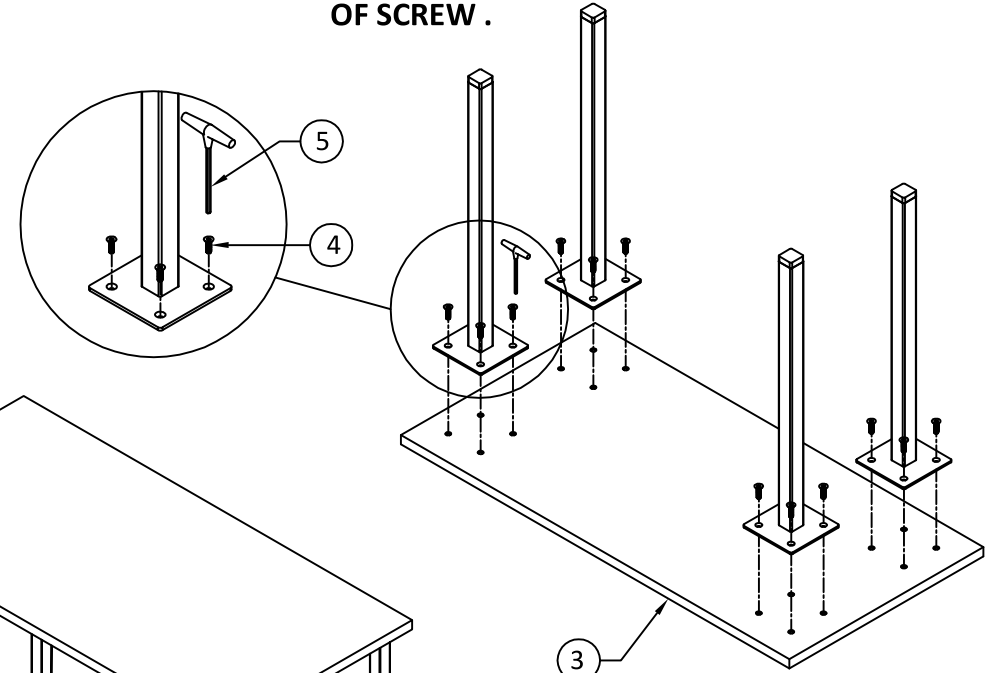

STEP 3. FINAL ASSEMBLED PRODUCT

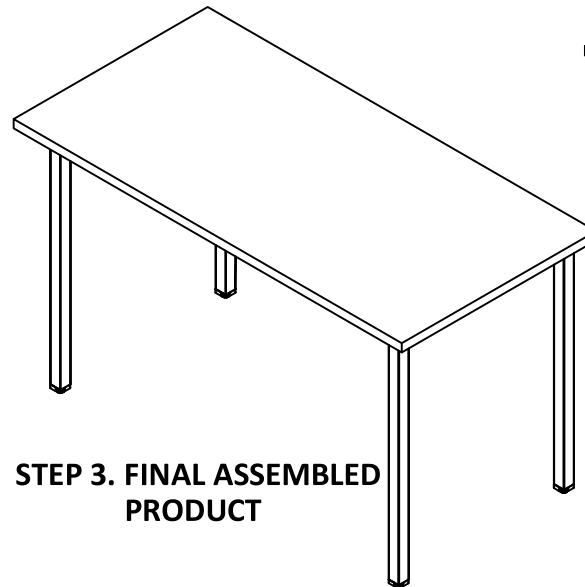

Maintenance Manual : Do's and Don't's

- Table tops should be cleaned using mild soap solution & wiped with dry cloth.
- Metal powder coated surfaces should be cleaned using gentle soft cloth
- Don't use thinner or water to clean stains from surfaces of table tops and metal powder coated parts.
- Don't place utensils containing liquid, hot material, sharp objects like knives, scissors which may damage or scratch the surface.
- Don't place hot objects such as electric skillets directly on table top surfaces as prolonged exposure to heat may cause damage.
- Chairs should be cleaned using dry cloth to wipe fabric wrapped seats, nylon base and metal power coated surfaces.
- Vacuum cleaning is recommended once in 3 months for chairs
- PET material should be cleaned with wet cloth/ disinfectant and should be stored in folded condition when not use.